

**Key data**

Moulded part	Front cover
Application	Mobile telephone
Part weight	3 g
Material	PC+ABS
Mould type	2K mould
No. of cavities	2+2

**Customer's requirements**

This application involved the production of mobile device cover of PC and ABS in a 2+2 cavity 2K family mould.

**Solution**

In the implementation of this application 2+2-port hot runner system with face fit manifold nozzles was employed. The cavity was directly gated with the hot runner to the moulding surface via open nozzles with torpedo. The system was supplied as the hot half, i.e. including mould plates, ready installed and adjusted as well as wired ready for plugging in and with the necessary hose connections.

**Benefits**

- Production without sprue waste and without reworking
- Good gating quality with respect to separation and appearance
- Uniform supply and filling of all cavities with melt
- Good moulding quality from all the cavities

**Schematic product overview**

1. Manifold nozzle ,face fit  
**Series CB...M, Type YT, Class 07 C**
2. Manifold  
**Series VC**

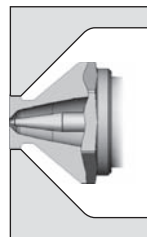
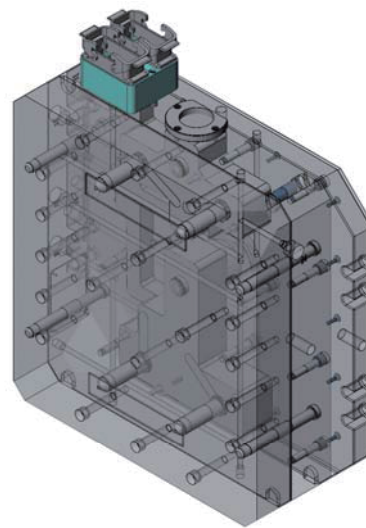

Y T



CB YT M

07 C + V C

