

**Key data**

Moulded part	Cover
Application	Mobile device
Part weight	15 g+25 g
Material	PC+ABS
Mould type	2K mould
No. of cavities	1+1

**Customer's requirements**

This application involved the production of a mobile device cover of PC and ABS in a 1+1 cavity 2K mould.

**Solution**

In the implementation of this application, each single valve gate nozzle was used for PC+ABS component. The manifold was of standard form(l) .The cavity was directly gated with the hot runner to the the moulding surface via valve gate, whereby the gate was recessed in a spherical dimple.

**Benefits**

- Production without sprue waste and without reworking
- Good gating quality with respect to separation and appearance

**Schematic product overview**

1. Manifold nozzle , face fit  
Series CB...M, Type WV, Class 07 C  
Series CB...M, Type YV, Class 07 C
2. Manifold  
Series VC
3. Cylinder, pneumatic, in mould plate  
Series LCP 4008 02

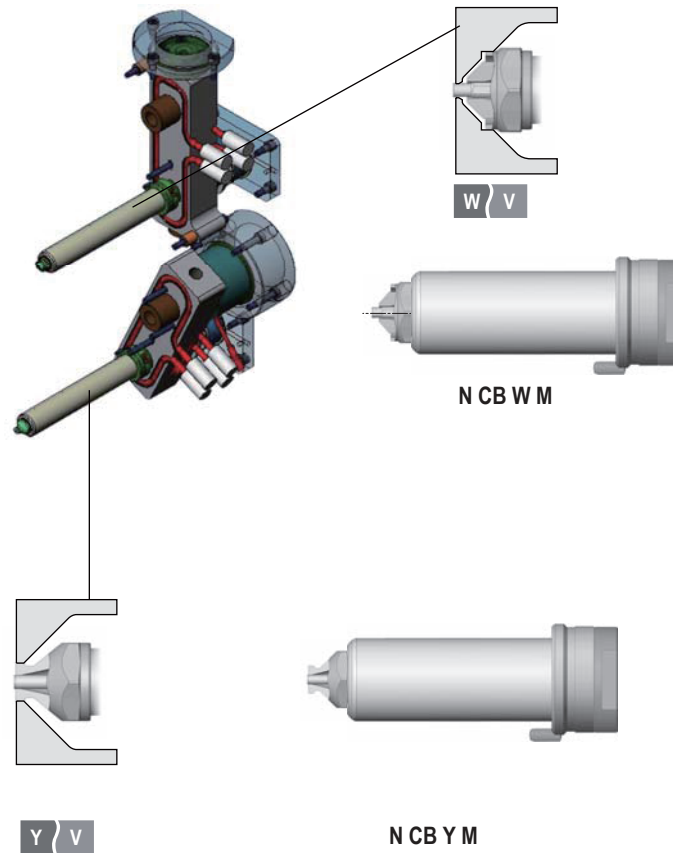

07 C + V C

