

# Series CB N ... S

## Single Nozzles, Valve Gate

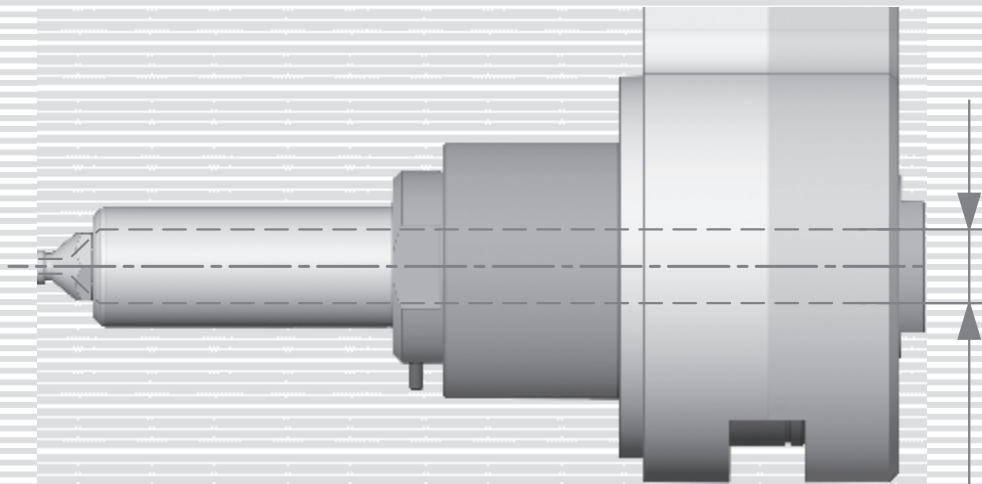

Ø7

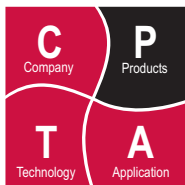

**Product type**

Hot runner nozzles in the **CB N ... S** range; this series belongs to nozzle class<sup>1)</sup> **07 S**.  
 → Nozzle size **07**: Flow bore-Ø 7 mm<sup>2)</sup>  
 → Nozzle style **S**: Single nozzle

With the nozzle tips in the form of screw-in parts, different nozzle types can be implemented (type = shape and gating of nozzle tip), see table at right.

Available gating types  
 → valve gate (**V**)

**Major dimensions (mm)**

<b>J</b>	Flow bore Ø	Ø7 <sup>2)</sup>
<b>L</b>	Nozzle length	33.5...243.5 <sup>3)4)</sup>
<b>D</b>	Ø of cut out, front	Ø27
<b>Dt</b>	Centring Ø tip	see right
<b>H</b>	Hot runner exit Ø	see right <sup>3)</sup>
<b>K</b>	Head height	105
<b>Dk</b>	Head Ø	Ø90
<b>Ls</b>	Depth of head centring	8
<b>Ds</b>	Ø of head centring	Ø80
<b>R</b>	Nozzle contact radius	max. 40
<b>AD</b>	Nozzle contact angle	90°/120°

**Heating**

- externally heated, 230 V AC
- 2...3 zones, 750...1000 W
- Fe/CuNi thermocouple, DIN 43710

**Application**

For all usual thermoplastics  
 Max. shot weight per nozzle (g)  
 → 80 (low viscosity)

Without being directly cooled the nozzle can be used up to a mould temperature of 80°C. For higher temperatures the associated cooling unit has to be used.

For further information about the cooling unit and also about details on the needle actuator (pressure, stroke etc.) please see section "Flow Control - Valve Gate Components"



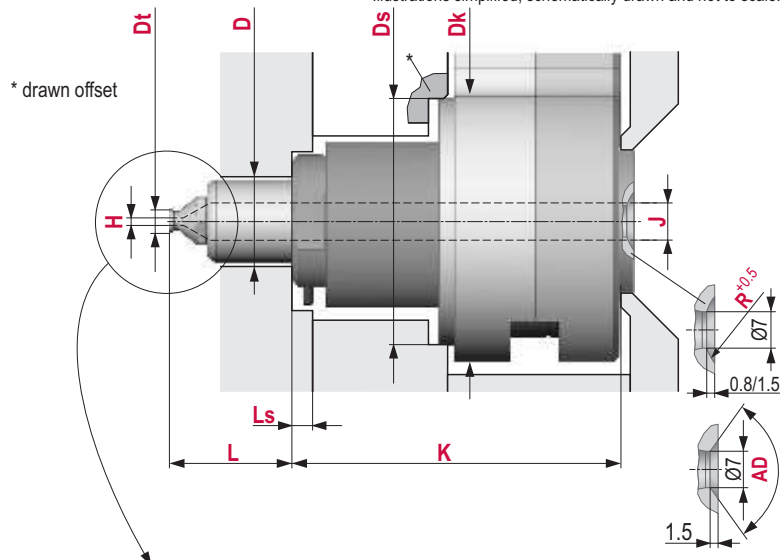

☞ page no. of related data sheets

- 1) Enhanced classification for improved ease of selection. Part of the nozzle type No. for later nozzle series.
- 2) Standard value resp. average diameter of nozzle range, can be different depending on nozzle series and application.
- 3) Raster dimensions. Intermediate values can be found from the prescribed dimensional raster.
- 4) Minimum and maximum value of nozzle length depend on the selected tip shape.

Illustrations simplified, schematically drawn and not to scale.



**Available nozzle types for this series**

Shape of nozzle tip	Gating of nozzle tip		
	N (open)	T (open with torpedo)	V (valve gate)
<b>Y</b>			 <b>YV</b> H: 2.4 Dt: Ø 7
<b>U</b>			
<b>F</b>			
<b>P</b>			
<b>K</b>			
<b>L</b>			 <b>LV</b> H: 2.4 Dt: Ø 7
<b>S</b>			
<b>V</b>			
<b>W</b>			 <b>WV</b> H: 1.6...2.4 Dt: Ø 14
<b>X</b>			 <b>XV</b> H: 1.6...2.4 Dt: Ø 14

S

C

E

**Cut out in mould plate for nozzle and connections**

**1. Cut out for the nozzle**

L Nozzle length

General tolerances: DIN ISO 2768-mK

Surfaces:  $\frac{3.2}{\nabla} / \left( \frac{1.6}{\nabla} / \frac{0.8}{\nabla} \right)$

Values of the dimension L can be found in the data sheet for the selected nozzle type.

**2. Cut out for connections**

- electrical power
- thermocouple
- compressed air

**3. Groove for locking pin**

The locking pin secures the nozzle against rotation.

**4. Cut out for the nozzle tip**

- a) Through bore nozzle tip (Y...V)
- b) Blind bore nozzle tip (W, X)

Dt Tip Ø  
H Hot runner gate Ø

Depending on the selected nozzle type, different cut outs are required for the nozzle tip.

The dimensions of the cut out for the nozzle tip used can be found in the nozzle data sheet.

1) These data apply for valve gate nozzles.

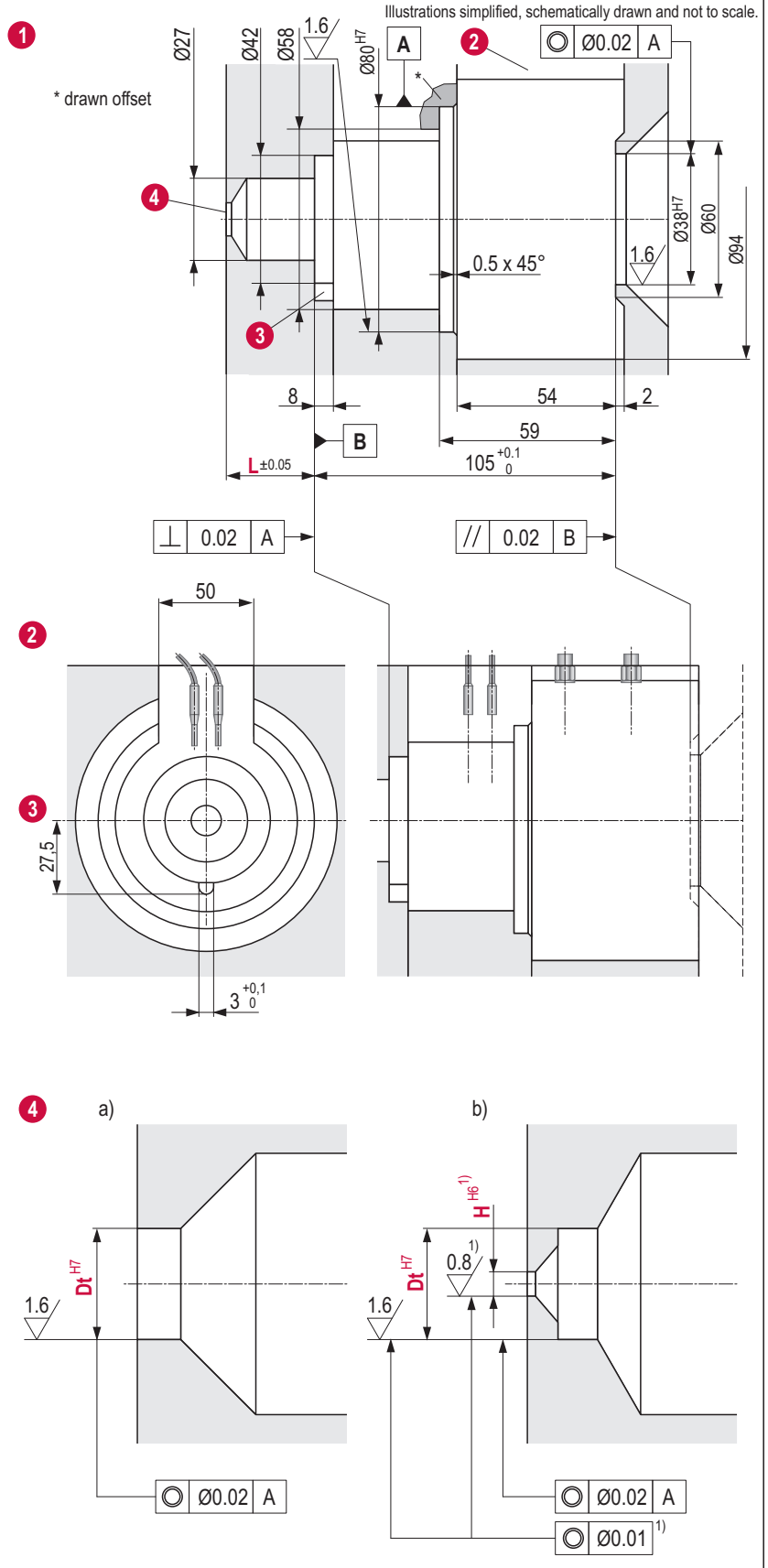

**You can configure your nozzle here**

1. Complete the nozzle description <sup>1)</sup>

**CB N Y01 S**  
Series & Type ↑ Length code ↑

2. Selection of variables

L=↑ H=↑ R=↑ AD=↑

**Example and explanations**

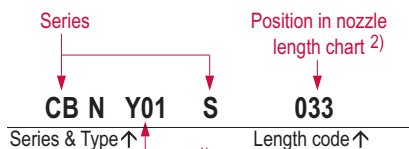

- Y Nozzle tip shape Y
- 01 Version 01: for materials with narrow to medium process window
- N Gating type: valve gate (V) <sup>1)</sup>

**33.5 2.4 16 -**  
L=↑ H=↑ R=↑ AD=↑

↑ Variables for precise nozzle specification from the drawings and tables shown here

H (mm)
2.4

R (mm)
max. 40

R = ... 25	T (mm)	R = 25.1 ... 40
1.5		0.8

AD (°)	
90	120

- 1) Nomenclature differences between older and newer nozzle series result from the revision of the nozzle range.
- 2) Depending on the nozzle series, the length code corresponds either to a particular nozzle length or to a range of lengths.
- 3) The numbering of the heating zones starts at the nozzle tip and ends at the nozzle head.

Illustrations simplified, schematically drawn and not to scale.

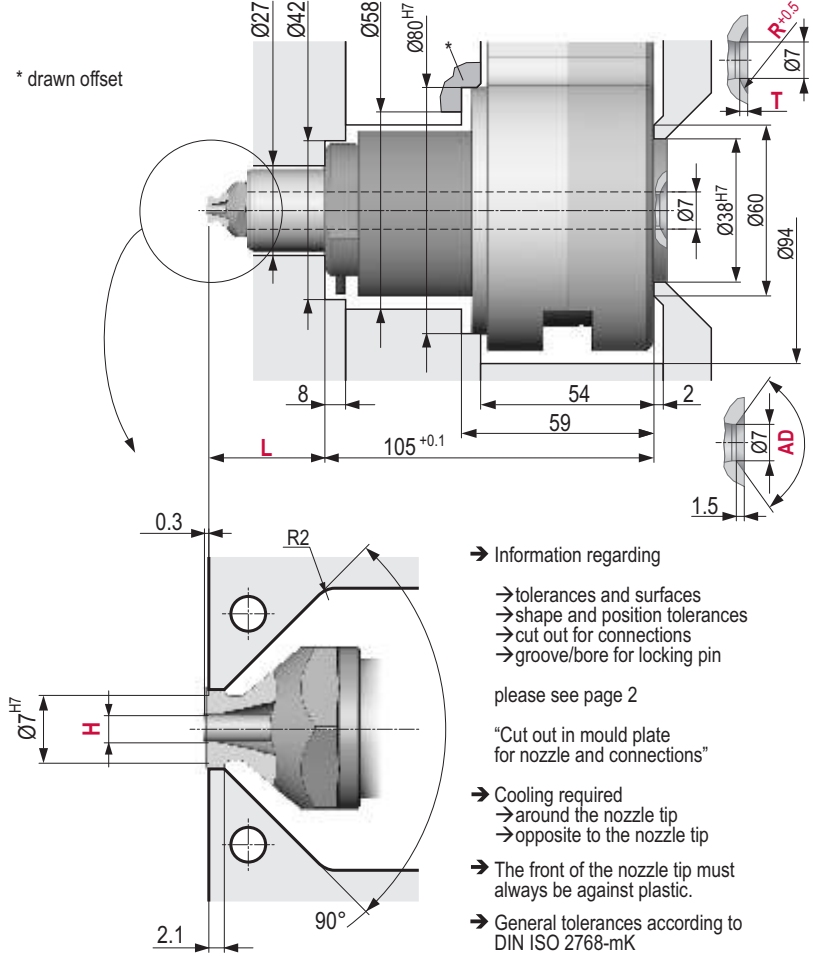

- Information regarding
  - tolerances and surfaces
  - shape and position tolerances
  - cut out for connections
  - groove/bore for locking pin
- please see page 2
- "Cut out in mould plate for nozzle and connections"
- Cooling required
  - around the nozzle tip
  - opposite to the nozzle tip
- The front of the nozzle tip must always be against plastic.
- General tolerances according to DIN ISO 2768-mK

Length code	L (mm)	L1 (mm)	L2 (mm)	Heater zones power <sup>3)</sup> (Watt)					
				1	2	3	4	5	1..5
033	33.5	-	-	250	500	-	-	-	750
043	43.5	-	-	250	500	-	-	-	750
053	53.5	-	-	250	500	-	-	-	750
063	63.5	-	-	250	500	-	-	-	750
073	73.5	-	-	250	500	-	-	-	750
083	83.5	-	-	250	500	-	-	-	750
093	93.5	-	-	315	500	-	-	-	815
103	103.5	-	-	315	500	-	-	-	815
113	113.5	-	-	315	500	-	-	-	815
123	123.5	-	-	315	500	-	-	-	815
133	133.5	-	-	315	500	-	-	-	815
143	143.5	-	-	180	180	500	-	-	860
153	153.5	-	-	180	180	500	-	-	860
163	163.5	-	-	180	180	500	-	-	860
173	173.5	-	-	180	180	500	-	-	860
183	183.5	-	-	180	180	500	-	-	860
193	193.5	-	-	250	180	500	-	-	930
203	203.5	-	-	250	180	500	-	-	930
213	213.5	-	-	250	180	500	-	-	930
223	223.5	-	-	250	250	500	-	-	1000
233	233.5	-	-	250	250	500	-	-	1000
246	243.5	-	-	250	250	500	-	-	1000

**You can configure your nozzle here**

1. Complete the nozzle description <sup>1)</sup>

**CB N L01 S**

Series & Type ↑ Length code ↑

2. Selection of variables

L=↑ H=↑ F=↑ R=↑ AD=↑

**Example and explanations**

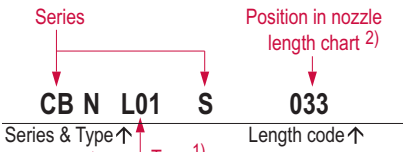

- L Nozzle tip shape Y
- 01 Version 01: for materials with narrow to medium process window
- N Gating type: valve gate (V) <sup>1)</sup>

**33.5 2.4 10 16 -**  
L=↑ H=↑ F=↑ R=↑ AD=↑

↑ Variables for precise nozzle specification from the drawings and tables shown here

<b>H (mm)</b>	2.4
<b>F (mm)</b>	10
<b>R (mm)</b>	max. 40
<b>R = ... 25 T (mm) R = 25.1 ... 40</b>	1.5 0.8
<b>AD (°)</b>	90 120

- 1) Nomenclature differences between older and newer nozzle series result from the revision of the nozzle range.
- 2) Depending on the nozzle series, the length code corresponds either to a particular nozzle length or to a range of lengths.
- 3) The numbering of the heating zones starts at the nozzle tip and ends at the nozzle head.

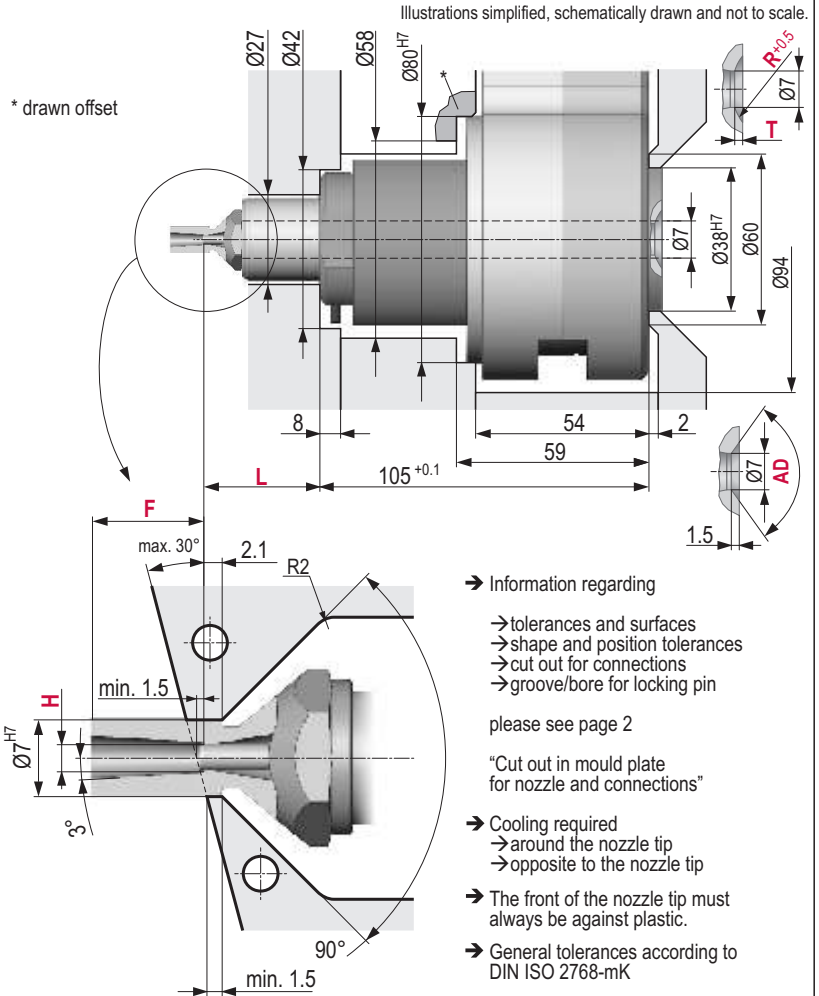

Length code	L (mm)	L1 (mm)	L2 (mm)	Heater zones power <sup>3)</sup> (Watt)					
				1	2	3	4	5	1..5
033	33.5	-	-	250	500	-	-	-	750
043	43.5	-	-	250	500	-	-	-	750
053	53.5	-	-	250	500	-	-	-	750
063	63.5	-	-	250	500	-	-	-	750
073	73.5	-	-	250	500	-	-	-	750
083	83.5	-	-	250	500	-	-	-	750
093	93.5	-	-	315	500	-	-	-	815
103	103.5	-	-	315	500	-	-	-	815
113	113.5	-	-	315	500	-	-	-	815
123	123.5	-	-	315	500	-	-	-	815
133	133.5	-	-	315	500	-	-	-	815
143	143.5	-	-	180	180	500	-	-	860
153	153.5	-	-	180	180	500	-	-	860
163	163.5	-	-	180	180	500	-	-	860
173	173.5	-	-	180	180	500	-	-	860
183	183.5	-	-	180	180	500	-	-	860
193	193.5	-	-	250	180	500	-	-	930
203	203.5	-	-	250	180	500	-	-	930
213	213.5	-	-	250	180	500	-	-	930
223	223.5	-	-	250	250	500	-	-	1000
233	233.5	-	-	250	250	500	-	-	1000
246	243.5	-	-	250	250	500	-	-	1000

**You can configure your nozzle here**

1. Complete the nozzle description <sup>1)</sup>

**CB N W01 S**  
Series & Type ↑ Length code ↑

2. Selection of variables

L=↑ H=↑ R=↑ AD=↑

**Example and explanations**

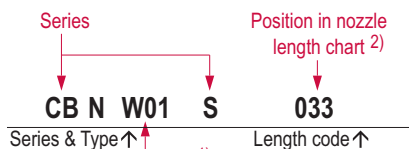

- W Nozzle tip shape V
- 01 Version 01: for materials with narrow to medium process window
- N Gating type: valve gate (V) <sup>1)</sup>

**33.5 2.4 16 -**  
L=↑ H=↑ R=↑ AD=↑

↑ Variables for precise nozzle specification from the drawings and tables shown here

H (mm)			
1.6	1.8	2.1	2.4

R (mm)	
max. 40	

R = ... 25	T (mm)	R = 25.1 ... 40
1.5		0.8

AD (°)	
90	120

- 1) Nomenclature differences between older and newer nozzle series result from the revision of the nozzle range.
- 2) Depending on the nozzle series, the length code corresponds either to a particular nozzle length or to a range of lengths.
- 3) The numbering of the heating zones starts at the nozzle tip and ends at the nozzle head.

Illustrations simplified, schematically drawn and not to scale.

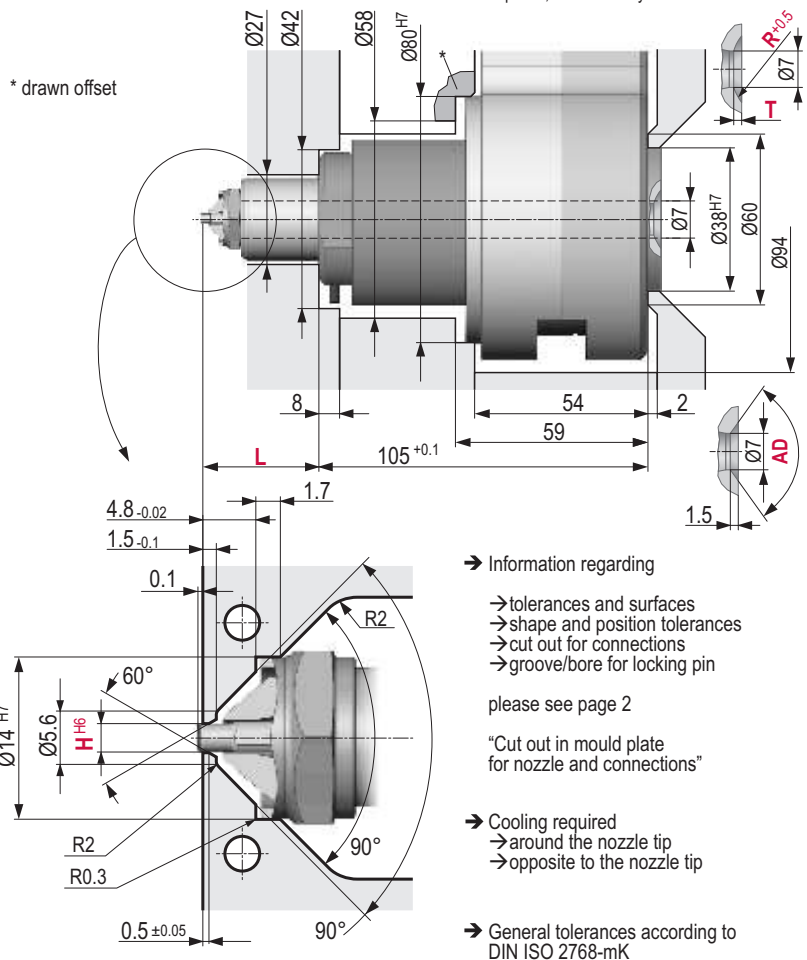

- Information regarding
  - tolerances and surfaces
  - shape and position tolerances
  - cut out for connections
  - groove/bore for locking pin

please see page 2

"Cut out in mould plate for nozzle and connections"

- Cooling required
  - around the nozzle tip
  - opposite to the nozzle tip

→ General tolerances according to DIN ISO 2768-mK

Length code	L (mm)	L1 (mm)	L2 (mm)	Heater zones power <sup>3)</sup> (Watt)					
				1	2	3	4	5	1..5
033	33.5	-	-	250	500	-	-	-	750
043	43.5	-	-	250	500	-	-	-	750
053	53.5	-	-	250	500	-	-	-	750
063	63.5	-	-	250	500	-	-	-	750
073	73.5	-	-	250	500	-	-	-	750
083	83.5	-	-	250	500	-	-	-	750
093	93.5	-	-	315	500	-	-	-	815
103	103.5	-	-	315	500	-	-	-	815
113	113.5	-	-	315	500	-	-	-	815
123	123.5	-	-	315	500	-	-	-	815
133	133.5	-	-	315	500	-	-	-	815
143	143.5	-	-	180	180	500	-	-	860
153	153.5	-	-	180	180	500	-	-	860
163	163.5	-	-	180	180	500	-	-	860
173	173.5	-	-	180	180	500	-	-	860
183	183.5	-	-	180	180	500	-	-	860
193	193.5	-	-	250	180	500	-	-	930
203	203.5	-	-	250	180	500	-	-	930
213	213.5	-	-	250	180	500	-	-	930
223	223.5	-	-	250	250	500	-	-	1000
233	233.5	-	-	250	250	500	-	-	1000
246	243.5	-	-	250	250	500	-	-	1000

**You can configure your nozzle here**

1. Complete the nozzle description <sup>1)</sup>

**CB N X01 S**

Series & Type ↑ Length code ↑

2. Selection of variables

L=↑ H=↑ R=↑ AD=↑

**Example and explanations**

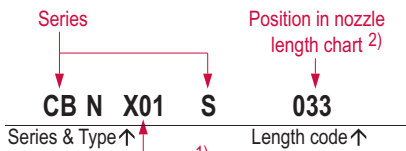

- X Nozzle tip shape X
- 01 Version 01: for materials with medium to wide process window
- N Gating type: valve gate (V) <sup>1)</sup>

**33.5 2.4 16 -**  
L=↑ H=↑ R=↑ AD=↑

↑ Variables for precise nozzle specification from the drawings and tables shown here

H (mm)			
1.6	1.8	2.1	2.4

R (mm)	
max. 40	

R = ... 25	T (mm)	R = 25.1 ... 40
1.5		0.8

AD (°)	
90	120

- 1) Nomenclature differences between older and newer nozzle series result from the revision of the nozzle range.
- 2) Depending on the nozzle series, the length code corresponds either to a particular nozzle length or to a range of lengths.
- 3) The numbering of the heating zones starts at the nozzle tip and ends at the nozzle head.

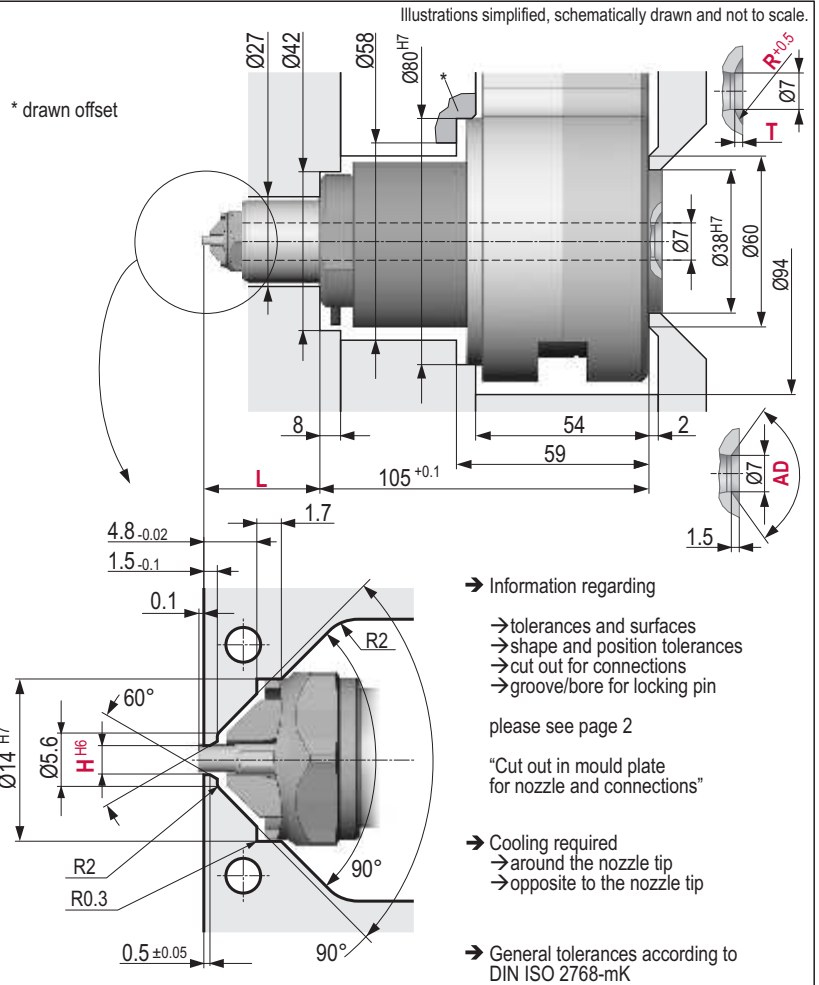

Length code	L (mm)	L1 (mm)	L2 (mm)	Heater zones power <sup>3)</sup> (Watt)					
				1	2	3	4	5	1..5
033	33.5	-	-	250	500	-	-	-	750
043	43.5	-	-	250	500	-	-	-	750
053	53.5	-	-	250	500	-	-	-	750
063	63.5	-	-	250	500	-	-	-	750
073	73.5	-	-	250	500	-	-	-	750
083	83.5	-	-	250	500	-	-	-	750
093	93.5	-	-	315	500	-	-	-	815
103	103.5	-	-	315	500	-	-	-	815
113	113.5	-	-	315	500	-	-	-	815
123	123.5	-	-	315	500	-	-	-	815
133	133.5	-	-	315	500	-	-	-	815
143	143.5	-	-	180	180	500	-	-	860
153	153.5	-	-	180	180	500	-	-	860
163	163.5	-	-	180	180	500	-	-	860
173	173.5	-	-	180	180	500	-	-	860
183	183.5	-	-	180	180	500	-	-	860
193	193.5	-	-	250	180	500	-	-	930
203	203.5	-	-	250	180	500	-	-	930
213	213.5	-	-	250	180	500	-	-	930
223	223.5	-	-	250	250	500	-	-	1000
233	233.5	-	-	250	250	500	-	-	1000
246	243.5	-	-	250	250	500	-	-	1000

[www.synventive.com](http://www.synventive.com)

MK-PRM.BRM.GB-P.ICB\_NS 2009-05-01

 **Synventive**  
molding solutions