

Series GA N ... S

Single Nozzles, Valve Gate

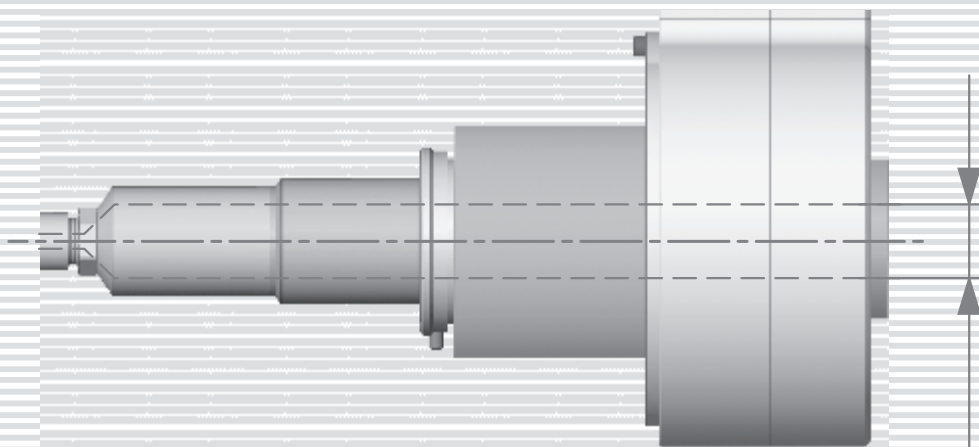

Ø12

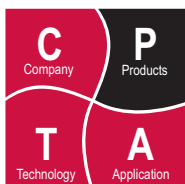

Product type

Hot runner nozzles in the **GA N ... S** range; this series belongs to nozzle class¹⁾ **12 S**.
 → Nozzle size **12**: Flow bore-Ø 12 mm²⁾
 → Nozzle style **S**: Single nozzle

With the nozzle tips in the form of screw-in parts, different nozzle types can be implemented (type = shape and gating of nozzle tip), see table at right.

Available gating types
 → valve gate (**V**)

Major dimensions (mm)

J	Flow bore Ø	Ø12 ²⁾
L	Nozzle length	48...297 ³⁾⁴⁾
D	Ø of cut out, front	Ø40
Dt	Centring Ø tip	see right
H	Hot runner exit Ø	see right ³⁾
L1	Length of cut out, back	0...170 ³⁾⁵⁾
D1	Ø of cut out, back	Ø46 ⁵⁾
K	Head height	139
Dk	Head Ø	Ø121
Ls	Depth of head centring	7.5
Ds	Ø of head centring	Ø110
R	Nozzle contact radius	0...40 ³⁾
AD	Nozzle contact angle	90°/120°

Heating

- externally heated, 230 V AC
- 2...3 Zonen, 1050...1650 W
- Fe/CuNi thermocouple, DIN 43710

Application

For all usual thermoplastics
 Max. shot weight per nozzle (g)
 → 300 (low viscosity)

Without being directly cooled the nozzle can be used up to a mould temperature of 80°C. For higher temperatures the associated cooling unit has to be used.

For further information about the cooling unit and also about details on the needle actuator (pressure, stroke etc.) please see section "Flow Control - Valve Gate Components"





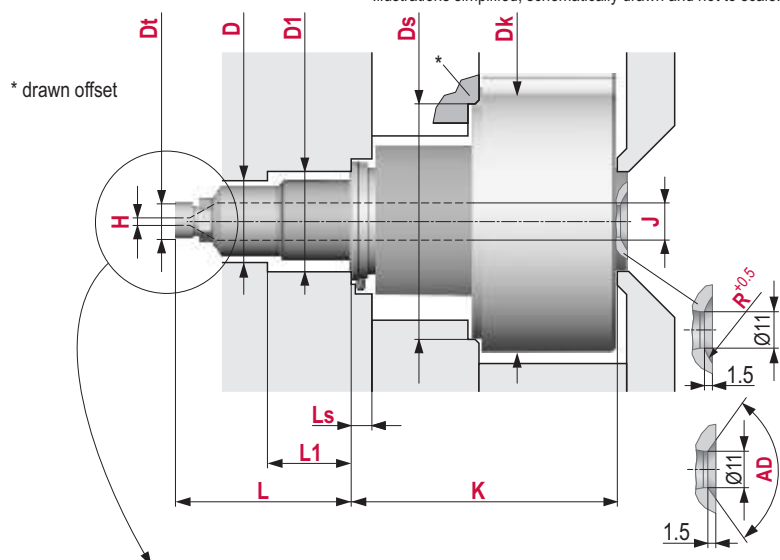

☞ page no. of related data sheets

- 1) Enhanced classification for improved ease of selection. Part of the nozzle type No. for later nozzle series.
- 2) Standard value resp. average diameter of nozzle range, can be different depending on nozzle series and application.
- 3) Raster dimensions. Intermediate values can be found from the prescribed dimensional raster.
- 4) Minimum and maximum value of nozzle length depend on the selected tip shape.
- 5) depending on nozzle length

Illustrations simplified, schematically drawn and not to scale.



Available nozzle types for this series

	Shape of nozzle tip		Gating of nozzle tip	
	N (open)	T (open with torpedo)	V (valve gate)	
Y			 YV H: 4.0 Dt: Ø 16	3
U				
F				
P				
K				
L			 LV H: 4.0 Dt: Ø 16	4
S			 SV H: 4.0 Dt: Ø 16	5
V			 VV H: 4.0 Dt: Ø 16	6
W			 WV H: 4.0 Dt: Ø 20	7...
X			 XV H: 3.0 / 4.0 Dt: Ø 16	8

S

C

E

You can configure your nozzle here

1. Complete the nozzle description ¹⁾

GA N Y01 S
Series & Type ↑ Length code ↑

2. Selection of variables

L=↑* H=↑ R=↑ AD=↑
*equal to the value of the length code for this series

Example and explanations

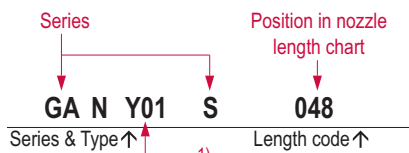

- Y Nozzle tip shape Y
- 01 → for materials with narrow to medium process window
- N Gating type: valve gate (V) ¹⁾

48 4.0 16 -
L=↑ H=↑ R=↑ AD=↑

↑ Variables for precise nozzle specification from the drawings and tables shown here

H (mm)
4.0

R (mm)
0 7.5 12.7 15.5 16 19 20 40

AD (°)
90 120

- 1) Nomenclature differences between older and newer nozzle series result from the revision of the nozzle range.
- 2) Depending on the nozzle series, the length code corresponds either to a particular nozzle length or to a range of lengths.
- 3) The numbering of the heating zones starts at the nozzle tip and ends at the nozzle head.

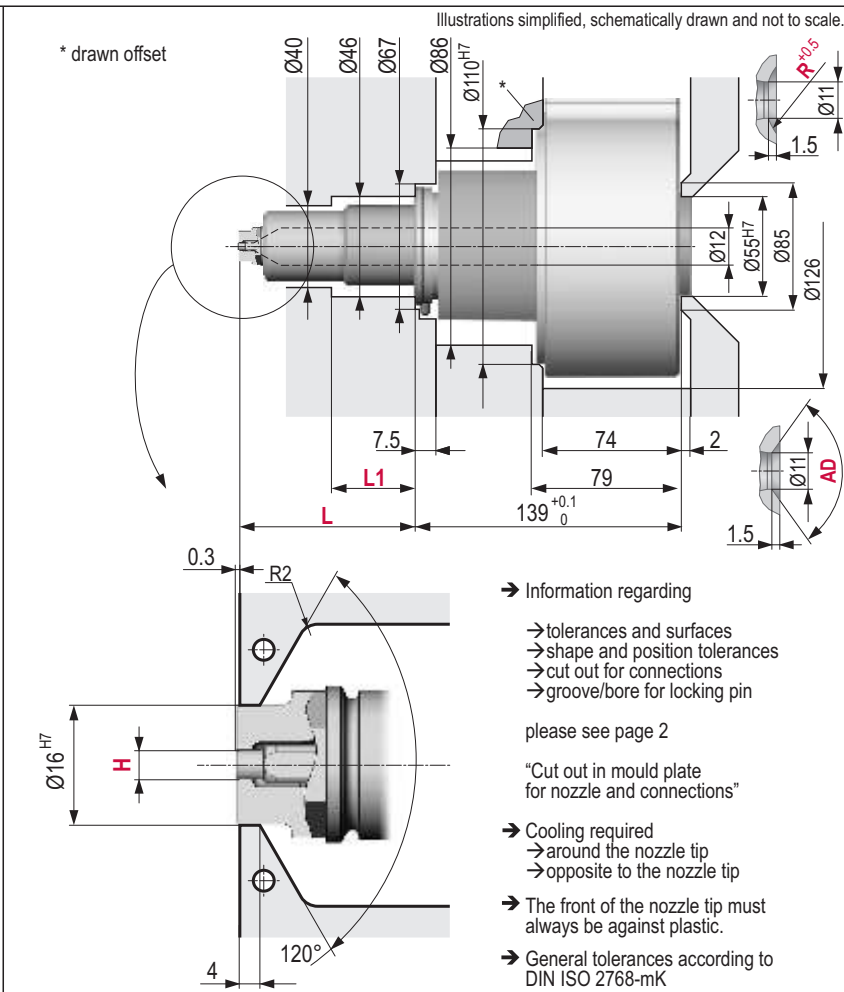

Length code	L (mm)	L1 (mm)	L2 (mm)	Heater zones power ³⁾ (Watt)					
				1	2	3	4	5	1..5
048	48	-	-	400	-	650	-	-	1050
078	78	-	-	500	-	650	-	-	1150
108	108	-	-	630	-	650	-	-	1280
138	138	60	-	400	400	650	-	-	1450
166	166	60	-	400	400	650	-	-	1450
196	196	80	-	400	400	650	-	-	1450
226	226	110	-	400	400	650	-	-	1450
256	256	140	-	400	400	650	-	-	1450
286	286	170	-	500	500	650	-	-	1650

You can configure your nozzle here

1. Complete the nozzle description ¹⁾

GA N L01 S

Series & Type ↑ Length code ↑

2. Selection of variables

L=↑* H=↑ F=↑ R=↑ AD=↑

*equal to the value of the length code for this series

Example and explanations

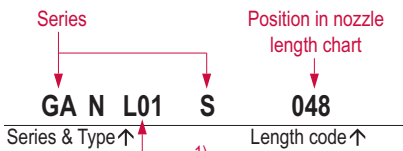

- L Nozzle tip shape L
- 01 → for materials with narrow to medium process window
- N Gating type: valve gate (V) ¹⁾

48 4.0 15 16 -
L=↑ H=↑ F=↑ R=↑ AD=↑

↑ Variables for precise nozzle specification from the drawings and tables shown here

H (mm)
4.0

F (mm)
15 50

G (°)
3

R (mm)
0 7.5 12.7 15.5 16 19 20 40

AD (°)
90 120

- 1) Nomenclature differences between older and newer nozzle series result from the revision of the nozzle range.
- 2) Depending on the nozzle series, the length code corresponds either to a particular nozzle length or to a range of lengths.
- 3) The numbering of the heating zones starts at the nozzle tip and ends at the nozzle head.

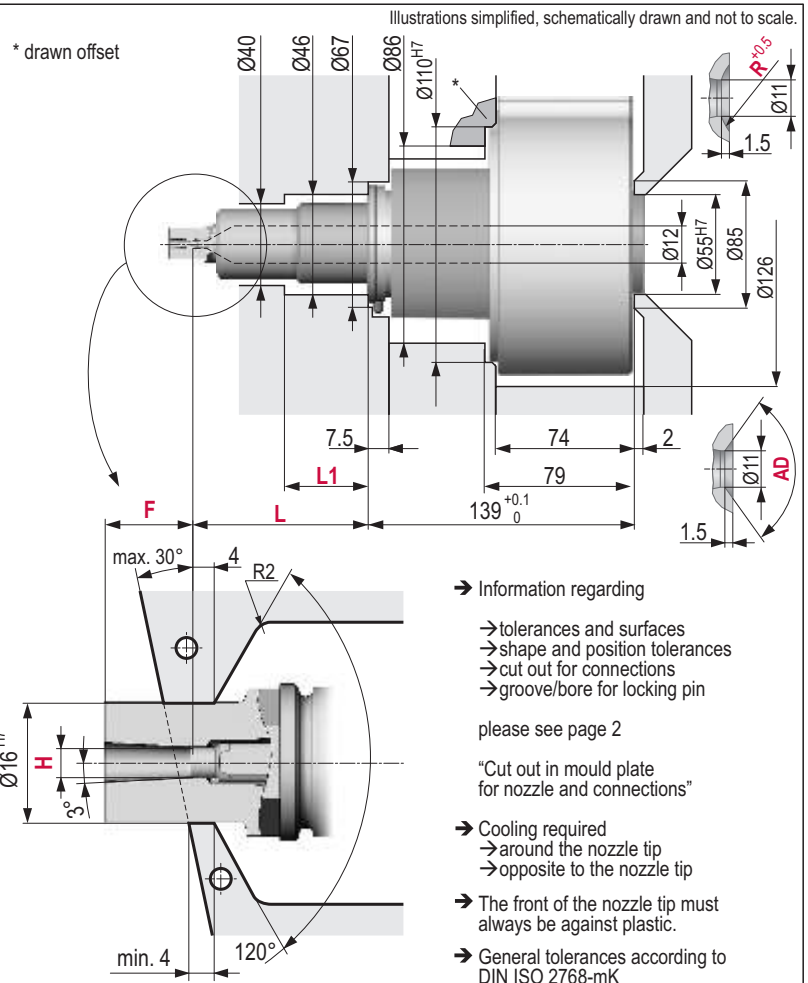

Length code	L (mm)	L1 (mm)	L2 (mm)	Heater zones power ³⁾ (Watt)					
				1	2	3	4	5	1..5
048	48	-	-	400	-	650	-	-	1050
078	78	-	-	500	-	650	-	-	1150
108	108	-	-	630	-	650	-	-	1280
138	138	60	-	400	400	650	-	-	1450
166	166	60	-	400	400	650	-	-	1450
196	196	80	-	400	400	650	-	-	1450
226	226	110	-	400	400	650	-	-	1450
256	256	140	-	400	400	650	-	-	1450
286	286	170	-	500	500	650	-	-	1650

You can configure your nozzle here

1. Complete the nozzle description ¹⁾

GA N S01 S
Series & Type ↑ Length code ↑

2. Selection of variables

L=↑* H=↑ F=↑ R=↑ AD=↑
*equal to the value of the length code for this series

Example and explanations

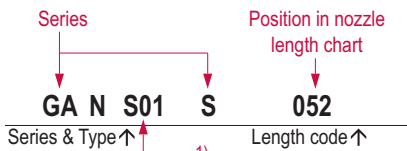

- S Nozzle tip shape S
- 01 →for materials with medium to wide process window
- N Gating type: valve gate (V) ¹⁾

52 4.0 15 16 -
L=↑ H=↑ F=↑ R=↑ AD=↑

↑ Variables for precise nozzle specification from the drawings and tables shown here

H (mm)	
4.0	

F (mm)	
15	50

G (°)	
3	

R (mm)					
0	7.5	12.7	15.5	16	19 20 40

AD (°)	
90	120

- 1) Nomenclature differences between older and newer nozzle series result from the revision of the nozzle range.
- 2) Depending on the nozzle series, the length code corresponds either to a particular nozzle length or to a range of lengths.
- 3) The numbering of the heating zones starts at the nozzle tip and ends at the nozzle head.

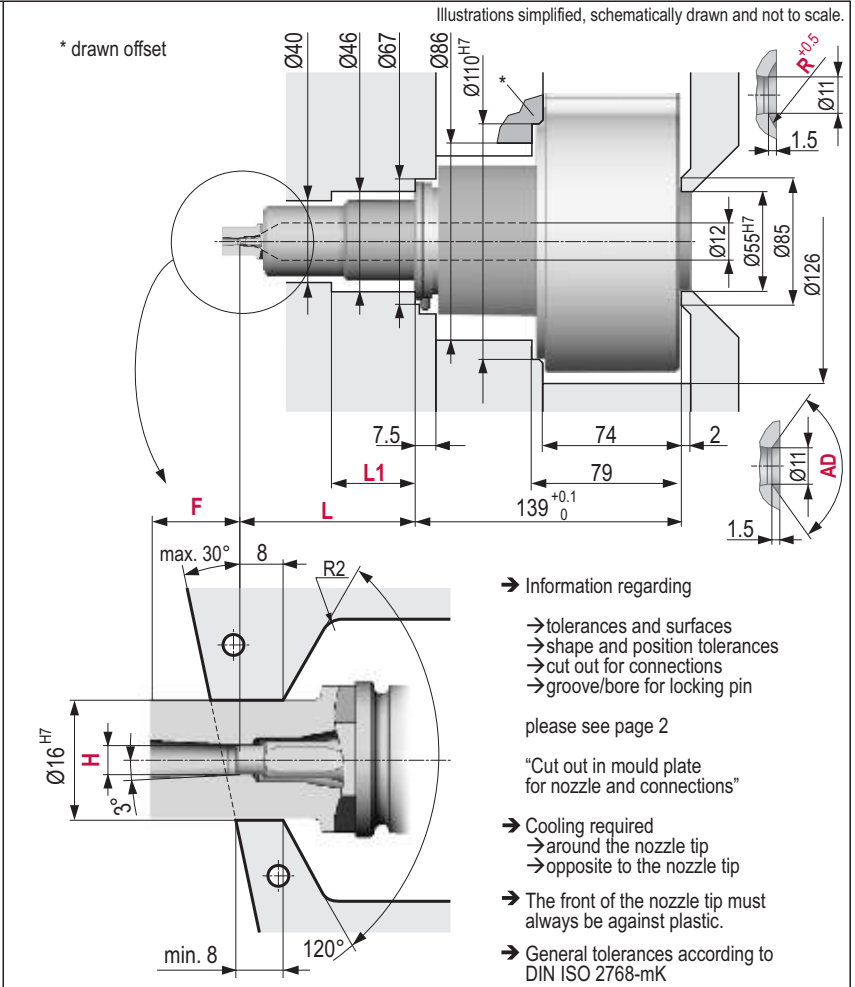

Length code	L (mm)	L1 (mm)	L2 (mm)	Heater zones power ³⁾ (Watt)					
				1	2	3	4	5	1..5
052	52	-	-	400	-	650	-	-	1050
082	82	-	-	500	-	650	-	-	1150
112	112	-	-	630	-	650	-	-	1280
142	142	60	-	400	400	650	-	-	1450
170	170	60	-	400	400	650	-	-	1450
200	200	80	-	400	400	650	-	-	1450
230	230	110	-	400	400	650	-	-	1450
260	260	140	-	400	400	650	-	-	1450
290	290	170	-	500	500	650	-	-	1650

You can configure your nozzle here

1. Complete the nozzle description ¹⁾

GA N V01 S

Series & Type ↑ Length code ↑

2. Selection of variables

L=↑* H=↑ F=↑ R=↑ AD=↑

*equal to the value of the length code for this series

Example and explanations

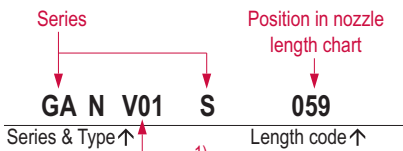

- V Nozzle tip shape V
- 01 → for materials with medium to wide process window
- N Gating type: valve gate (V) ¹⁾

59 4.0 15 16 -
L=↑ H=↑ F=↑ R=↑ AD=↑

↑ Variables for precise nozzle specification from the drawings and tables shown here

H (mm)	
4.0	

F (mm)			
0	15	30	50

F = 0 / 15 / 30		G (°)		F = 50 / 90	
3		1.5			

R (mm)					
0	7.5	12.7	15.5	16	19 20 40

AD (°)	
90	120

1) Nomenclature differences between older and newer nozzle series result from the revision of the nozzle range.
 2) Depending on the nozzle series, the length code corresponds either to a particular nozzle length or to a range of lengths.
 3) The numbering of the heating zones starts at the nozzle tip and ends at the nozzle head.

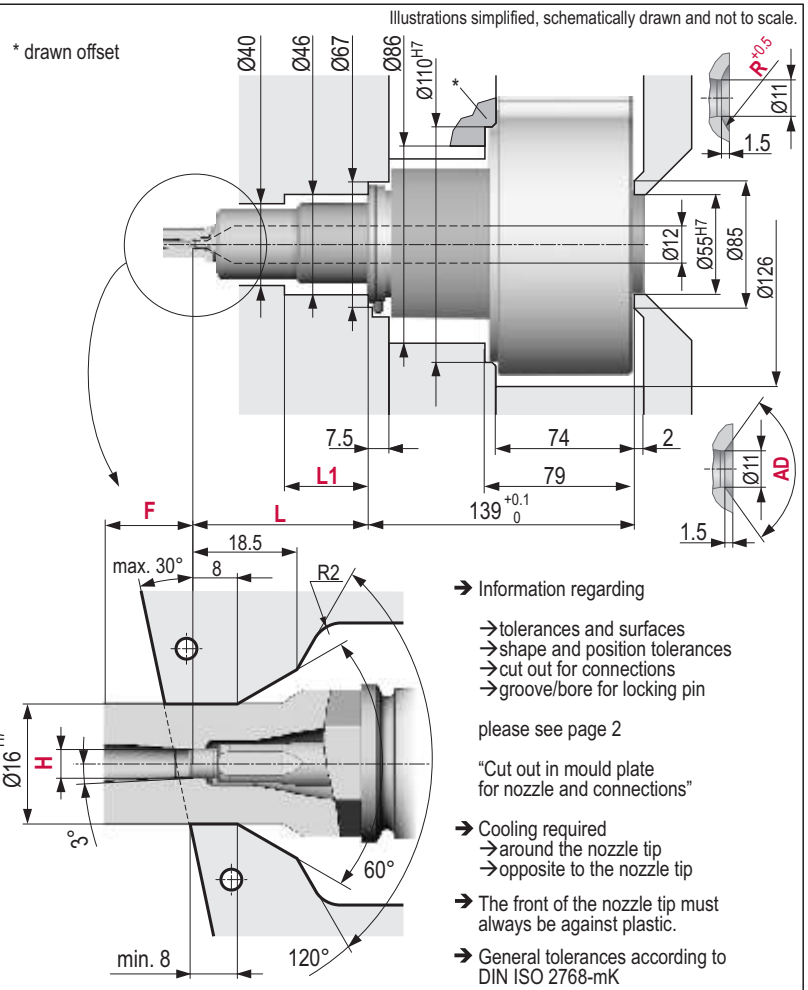

Length code	L (mm)	L1 (mm)	L2 (mm)	Heater zones power ³⁾ (Watt)					1..5
				1	2	3	4	5	
059	59	-	-	400	650	-	-	-	1050
089	89	-	-	500	650	-	-	-	1150
119	119	-	-	630	650	-	-	-	1280
149	149	60	-	400	400	650	-	-	1450
177	177	60	-	400	400	650	-	-	1450
207	207	80	-	400	400	650	-	-	1450
237	237	110	-	400	400	650	-	-	1450
267	267	140	-	400	400	650	-	-	1450
297	297	170	-	500	500	650	-	-	1650

You can configure your nozzle here

1. Complete the nozzle description ¹⁾

GA N W01 S

Series & Type ↑ Length code ↑

2. Selection of variables

L=↑* H=↑ R=↑ AD=↑

*equal to the value of the length code for this series

Example and explanations

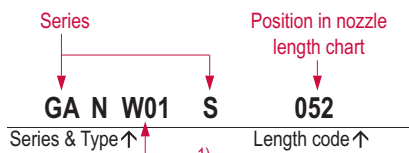

- W Nozzle tip shape W
- 01 Version 01: for materials with medium to wide process window
- N Gating type: valve gate (V) ¹⁾

52 4.0 16 -
L=↑ H=↑ R=↑ AD=↑

↑ Variables for precise nozzle specification from the drawings and tables shown here

H (mm)
4.0

R (mm)
0 7.5 12.7 15.5 16 19 20 40

AD (°)
90 120

- 1) Nomenclature differences between older and newer nozzle series result from the revision of the nozzle range.
- 2) Depending on the nozzle series, the length code corresponds either to a particular nozzle length or to a range of lengths.
- 3) The numbering of the heating zones starts at the nozzle tip and ends at the nozzle head.

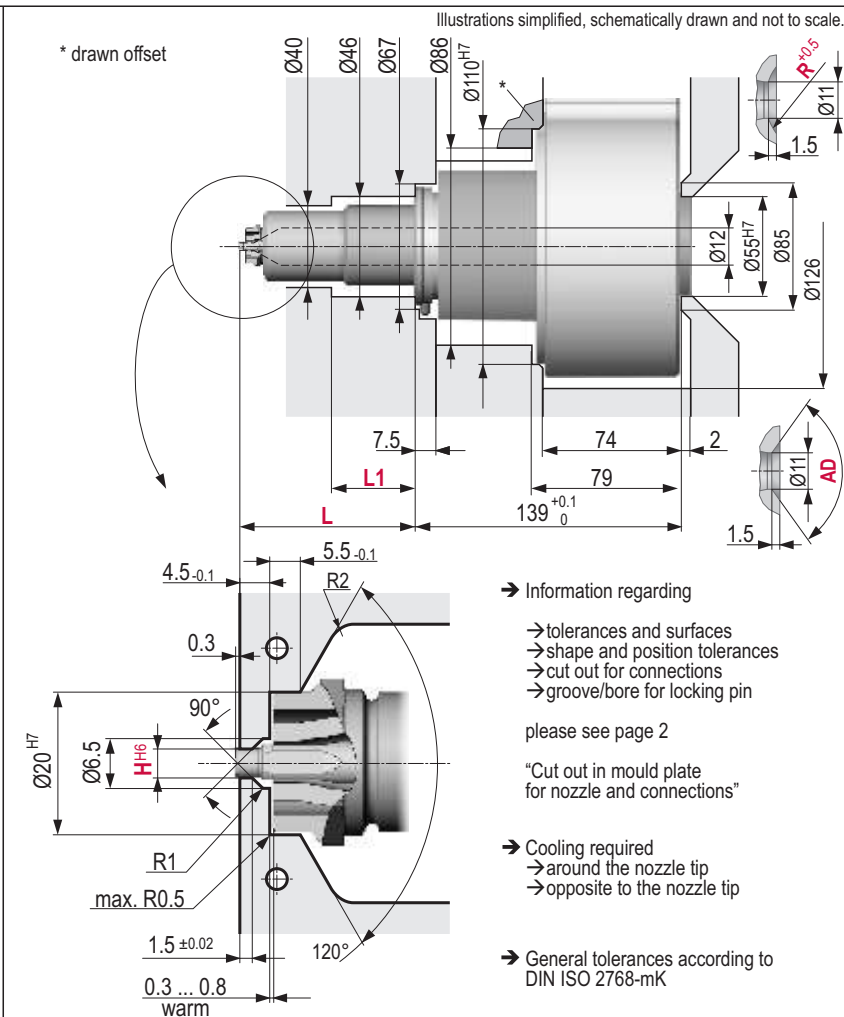

Length code	L (mm)	L1 (mm)	L2 (mm)	Heater zones power ³⁾ (Watt)					
				1	2	3	4	5	1..5
052	52	-	-	400	650	-	-	-	1050
082	82	-	-	500	650	-	-	-	1150
112	112	-	-	630	650	-	-	-	1280
142	142	60	-	400	400	650	-	-	1450
170	170	60	-	400	400	650	-	-	1450
200	200	80	-	400	400	650	-	-	1450
230	230	110	-	400	400	650	-	-	1450
260	260	140	-	400	400	650	-	-	1450
290	290	170	-	500	500	650	-	-	1650

You can configure your nozzle here

1. Complete the nozzle description ¹⁾

GA N X01 S
Series & Type ↑ Length code ↑

2. Selection of variables

L=↑* H=↑ R=↑ AD=↑
*equal to the value of the length code for this series

Example and explanations

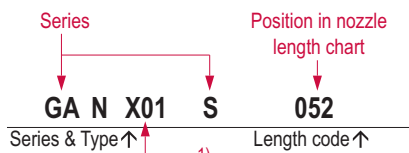

- X Nozzle tip shape X
- 01 Version 01: for materials with medium to wide process window
- N Gating type: valve gate (V) ¹⁾

52 4.0 16 -
L=↑ H=↑ R=↑ AD=↑

↑ Variables for precise nozzle specification from the drawings and tables shown here

H (mm)	
3.0	4.0

R (mm)					
0	7.5	12.7	15.5	16	19 20 40

AD (°)	
90	120

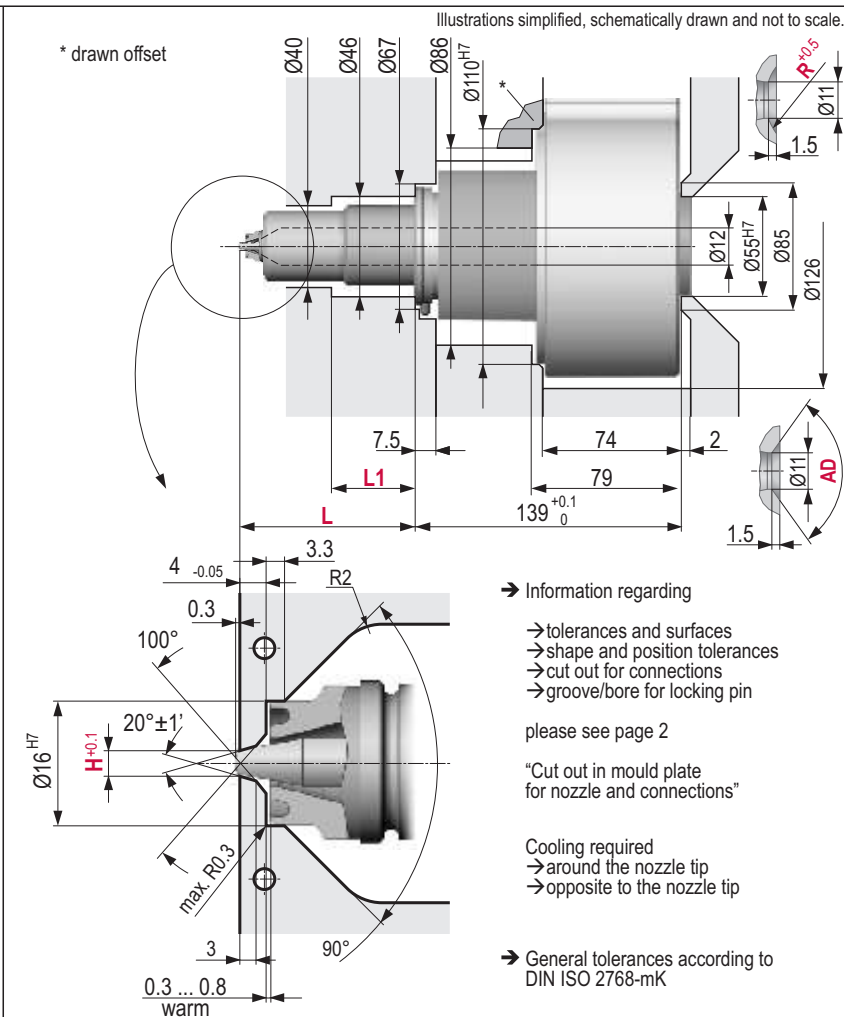

Length code	L (mm)	L1 (mm)	L2 (mm)	Heater zones power ³⁾ (Watt)					
				1	2	3	4	5	1..5
052	52	-	-	400	650	-	-	-	1050
082	82	-	-	500	650	-	-	-	1150
112	112	-	-	630	650	-	-	-	1280
142	142	60	-	400	400	650	-	-	1450
170	170	60	-	400	400	650	-	-	1450
200	200	80	-	400	400	650	-	-	1450
230	230	110	-	400	400	650	-	-	1450
260	260	140	-	400	400	650	-	-	1450
290	290	170	-	500	500	650	-	-	1650

www.synventive.com

MK-PRM.BRM.GB-P.IGA_NS 2009-05-01

 **Synventive**
molding solutions